



- FÁBRICA DE MAQUINARIA -
- MACHINERY FACTORY -

DOSIFICADORES[®]
garcía fernández

TAJO 200

GROUT CEMENT INJECTION MACHINE FOR CIVIL WORKS MODEL “TAJO 200”

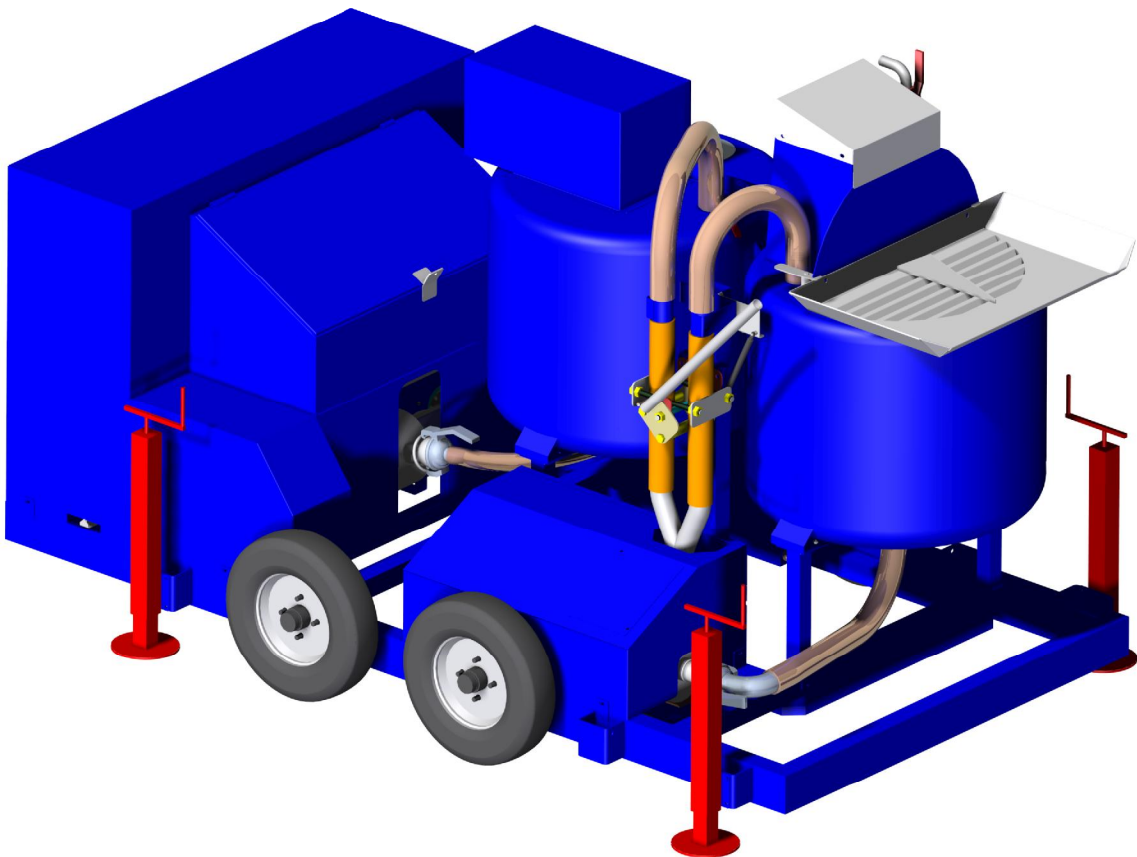

Polígono Industrial 2ª fase, 37 y 38. 29130 ALHAURIN DE LA TORRE. (MALAGA) -SPAIN-
Tel. (+0034) 952 41 16 70 – 952 41 38 53. Fax. (+0034) 952 41 19 18
dosificadores@dosificadoresgf.com www.dosificadoresgf.com



- FÁBRICA DE MAQUINARIA -
- MACHINERY FACTORY -

DOSIFICADORES[®]
garcía fernández

TAJO 200

Dimensions:

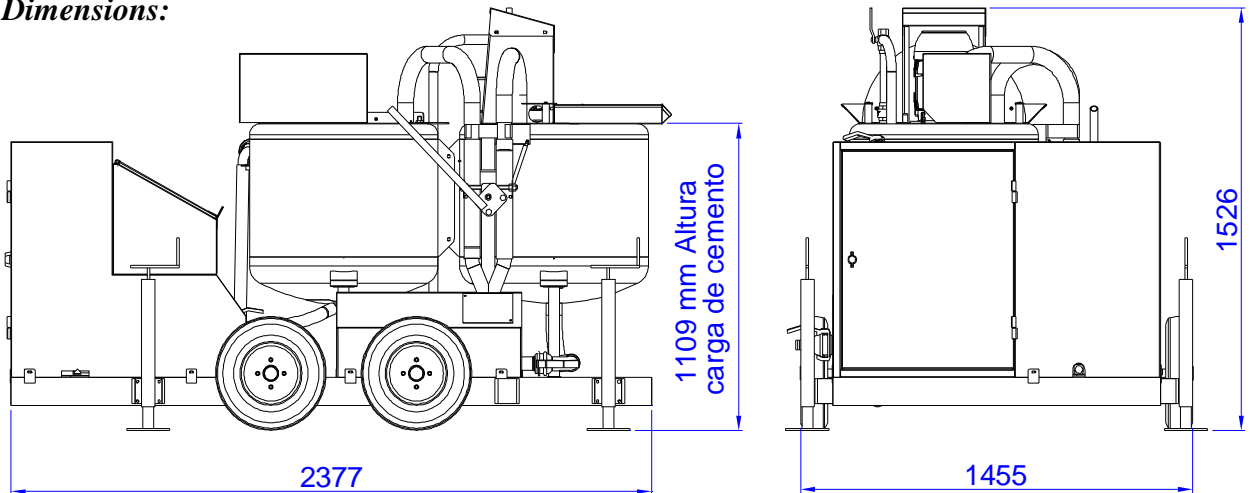

Machine weight: 600 Kg (without external elements)

Production capacity:

Grout cement injection doses from 105 to 210 Kg (3 to 6 sacks of 35 Kg). Grout cement injection with a double mixing: agitator disc of high speed and recirculation turbo.

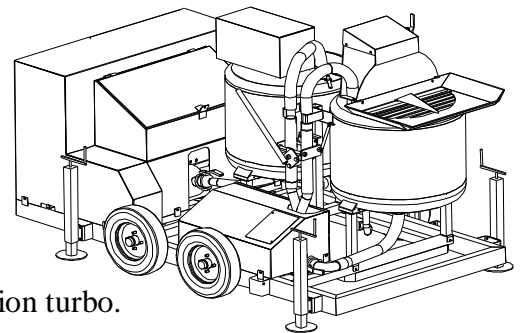

- § Water/ cement relation admissible with chemical additive: 0.36 (without chemical additive: 0.44).
- § Water dosage through pump dosage. Digital programming, resolution of 0,1 litre, with visual display screen and correctness factor.
- § Injection pressure: Regulable between 0.5 to 16 bar. Digital programming, resolution of 0,1 bar, with work and cut pressure visual display.
- § Injection pump flow: This is regulable to the operator desire between 2000 and 4000 litres/hour, mechanical variation.
- § Injection which is carried out through helicoid pump trade mark DGF, specifically design for the grout pumping, easily cleanliness. The cleanliness is carried out through the final water pumping.
- § Maintenance mixer with useful capacity of 175 litres, with suitable agitation in order to facilitate the exit of air.

Polígono Industrial 2ª fase, 37 y 38. 29130 ALHAURIN DE LA TORRE. (MALAGA) - SPAIN -
Tel. (+0034) 952 41 16 70 – 952 41 38 53. Fax. (+0034) 952 41 19 18
dosificadores@dosificadoresgf.com www.dosificadoresgf.com



- FÁBRICA DE MAQUINARIA -
- MACHINERY FACTORY -

DOSIFICADORES[®]
garcía fernández

TAJO 200

- **Absorbed Electric Power :**

§ Total: 15 Kw. 30 A

§ Apparently power: 21 KVA (Recommended generator 30 KVA). If it will be used a generator it is very important to start it up and leave it to reach its usually normal working before connecting and finishing with the machine and also must disconnect the machine before switch off the generator.

- **Main supply tension:** Three- phase 400V at 50 Hz. (For other configurations, please consult us).

- **Construction:**

§ Mixers which are built in stainless steel AISI 304 2B.

§ Chassis in carbon steel.

§ Pumps: which are covered and suitable protected.

§ Electric component box with a double door, the second one which transparent and all the electric component box is protected inside an electrical component box with a door.

§ Drawer with tools and accessories.

§ The entire machine (included mixers) painted on synthetic paint; the client will choose the color of the machine.

§ Four wheels for small displacements at the work and four legs for its fixed and leveling.

§ Four hooks for its leveling and corresponding slings.

§ The equipment will be supplied with an extra deposit of 1000 litres.

Ways of Leveling:

The machine leveling must be carried out through the slings which are supplied of 4 m length and 1000 Kg of capacity each one which are placed as it is showed on the following picture.

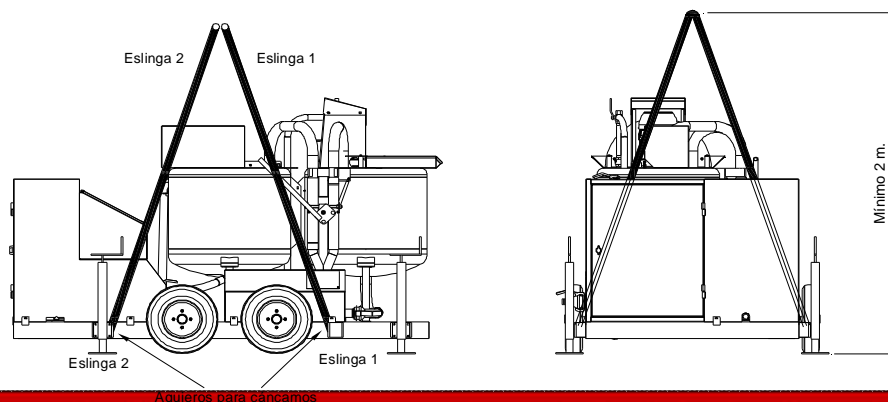

Polígono Industrial 2ª fase, 37 y 38. 29130 ALHAURIN DE LA TORRE. (MALAGA) -SPAIN-
Tel. (+0034) 952 41 16 70 – 952 41 38 53. Fax. (+0034) 952 41 19 18
dosificadores@dosificadoresgf.com www.dosificadoresgf.com



- FÁBRICA DE MAQUINARIA -
- MACHINERY FACTORY -

DOSIFICADORES[®]
garcía fernández

TAJO 200

Injection Equipment images:

The equipment will include all the elements which are necessary in order to carry out with all the injection works with exception of the tensile connection nozzles.

It has automatic water dosage, for this reason it includes a deposit of 1000 litres for its supply together with the uptake hose and filter element.

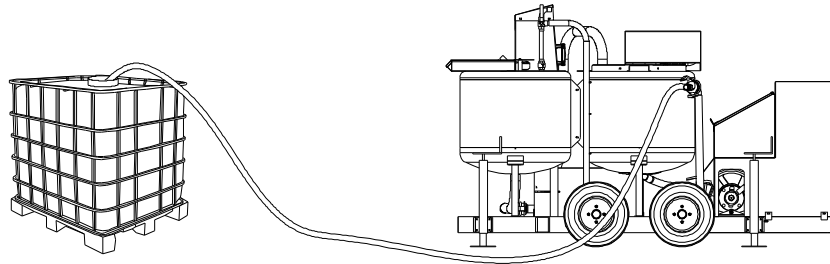

It also includes elements as outlet grout hoses, electric connectors, remote control, pumping and cleaning hose, etc.



Polígono Industrial 2ª fase, 37 y 38. 29130 ALHAURIN DE LA TORRE. (MALAGA) - SPAIN -
Tel. (+0034) 952 41 16 70 – 952 41 38 53. Fax. (+0034) 952 41 19 18
dosificadores@dosificadoresgf.com www.dosificadoresgf.com